

**CLEAN  
AIR**



**FOR  
WORKERS**

**Reduce machine operator exposure to harmful respirable dust, toxins, odors, and gases**

### **Protect Operators and Improve Air Quality**

- Patented, powered technology integrates precleaner, pressurizer, and high-efficiency filtration into a single, compact system
- Meet exposure reduction goals and health and safety initiatives, reduce exposure to harmful respirable particulate, odors, toxins, and gases with interchangeable filter offerings
- High-efficiency filtration arrests microscopic particles extending HVAC system maintenance intervals and filter life, reducing downtime and increasing productivity
- Achieve ISO 23875 Cab Air Quality Standard compliance

### **Protect Heavy Mobile Equipment Operators in High-debris Work Environments, including:**

- Mining
- Demolition
- Construction
- Quarries / aggregate
- Concrete processing
- Waste and recycling, landfills, and transfer stations
- Agricultural and harvesting
- Forestry and timber
- Other high-debris job sites

# RESPA<sup>®</sup> CF2 POWERED PRECLEANER FILTER / PRESSURIZER

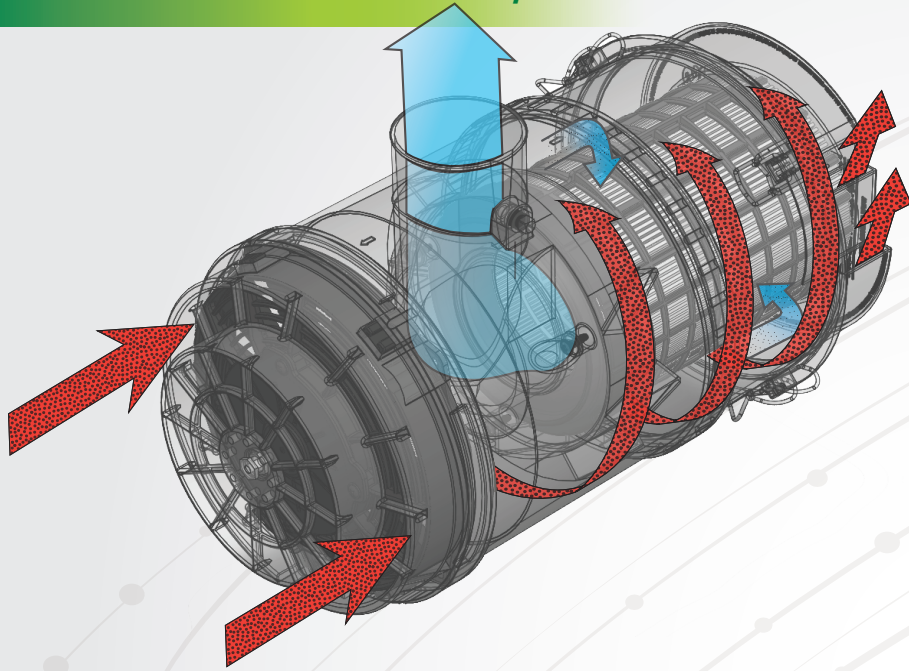

## How it Works: The "Sy-Klone Effect"

1. Dirty air enters the precleaner housing through the inlet end.
2. The debris-laden air is directed into a rotation – a "Sy-Klone" – pushing the debris to the outside walls through centrifugal force. The debris rotates towards the outlet end.
3. Debris is ejected through the ejection port, and the fine dust that remains passes through Sy-Klone's self-cleaning filter.
4. After passing through the high-efficiency filter, clean air is passed downstream to the HVAC system through the outlet end.

**The separation and ejection of debris, and high-efficiency filtering, all of which precleans air, is The Sy-Klone Effect.**

## Product Specifications

**Airflow range:** Ideal operation range: 0 CFM to 130 CFM (0 m<sup>3</sup>/min to 3.68 m<sup>3</sup>/min)  
Extended operation range: up to 250 CFM (7.08 m<sup>3</sup>/min)

**Motor/Voltage:** Compact Brushed Motor and Brushless Motor options, both in 12V or 24V

**Mounting:** Horizontal or Vertical with rain cap end up (Mounting plates available separately)

**Standard-length, compact motor, 3-inch outlet product dimensions and weight:** HxWxL; Weight  
With rain cap: 18.9" x 10" x 11.3" (479 x 254 x 286 mm); 10.5 lbs. (4.8kg)

**Extended-length, compact motor, 3-inch outlet product dimensions and weight:** HxWxL; Weight  
With rain cap: 23.9" x 10" x 11.3" (606 x 254 x 286 mm); 14.2 lbs. (6.4 kg)



## INTERCHANGEABLE FILTER OPTIONS TO SUIT YOUR JOB SITE

### PARTICULATE:

- HEPA • EPA • MERV 16

### GAS + PARTICULATE:

- ODOR • ABEK GAS • AMMONIA

