



WILLIBALD
RECYCLING TECHNOLOGY



FLEXSTAR

3000

SHREDDING - SCREENING - TURNING

FLEXSTAR 3000

POWERFUL AND PRECISE
SCREENING TECHNOLOGY THAT IMPRESSES

Once the original materials have been shredded and, depending on the initial material, turned over several times, everything has to be screened. That's because only perfect separation of the different-sized components by as fine a screening as possible delivers a perfect result.

The WILLIBALD FLEXSTAR 3000 screening system was designed to accurately screen and separately discharge biological material in a single work process, optionally in two or three fractions. Many different initial materials such as biomass, compost, pre-broken wood waste, bark mulch, wood chips and numerous other organic products can be perfectly processed in this way. The mobile screening system reveals its true strength where conditions are difficult for conventional screening technology. Damp and sticky bulk materials that tend to quickly stick to screen bases are screened out efficiently and economically.



Innovations



Transport position (total length only 10.3 m)



Two-fraction mode



Unique maintenance accessibility

Proven technology – THE HIGHLIGHTS

Convincing combination of accuracy, economy and maintenance friendliness in a compact form

The mobile, multi-fraction, high-performance FLEKSTAR 3000 screen is assembled on an 80 km/h two-axle chassis with ABS as standard and driven by a high-performance diesel engine. The compact design of the FLEKSTAR makes it highly mobile even in difficult space conditions. The enormous hopper (with a capacity of 8 cubic meters) enables permanently uniform feeding at a high throughput rate of up to 200 cubic meters per hour with exact separation.

The consistently high screening quality is influenced decisively by the speed of the star shafts. This is ensured by speed monitoring of the feeding and the screening decks. In addition, the quality of the end product can be changed by different interchangeable finger strips.

Moreover, the user can switch between two and three-fraction operation, as required, within just a few operating functions. For this, the fine deck (lower deck) is moved electro hydraulically out of the working area in the direction of the drawbar and the hydraulic functions fine deck drive and medium grain belt drive are stopped. The coarse deck, the overgrain belt and the fine grain discharge stay in operation. This unique system configuration combines the application possibility of a two-fraction screen and a three-fraction screening system – variably depending on requirements and the quality standards.

Important standard equipment



Feeding hopper

Optimum feeding and extra-large hopper volume with 8 cubic meters for best possible material feeding

Machine drive

Powerful Perkins engine with 159 HP /117 kW in the latest exhaust gas stage also available as an electric version



Maintenance concept

A lot of space for fast and reliable servicing and component replacement

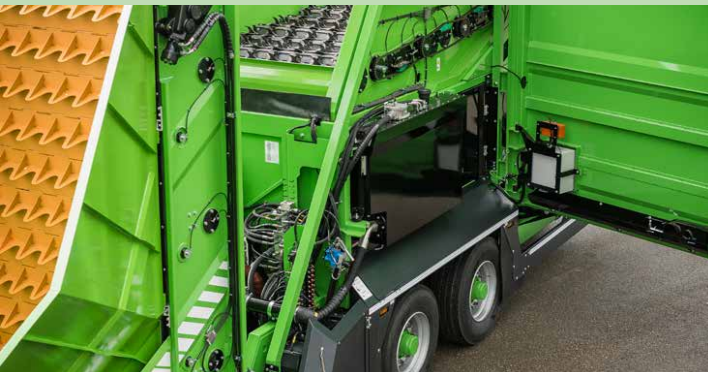

Modular screening decks

The screening decks for fine and coarse screening can be changed quickly and individually depending on the requirements of the end material



Strong and flexible finger strips

Every screen shaft is equipped both in the coarse stage and the fine stage with eight individually replaceable spring steel finger strips each in a choice of different sizes.



Equipment extras

Crawling speed drive

enables continuous depositing of the screened materials in closed windrows. The movement is driven by a friction wheel on two tires, controlled by control panel or remote control.



Radio remote control

enables convenient and reliable operation of all machine functions and basic settings such as, e.g., the feeding speed of the feeder from the feeding vehicle.

Central lubrication system

supplies all lubricating points of the screening system at adjustable intervals with the exact dose of your required grease volume.



LED work lights

Four LED work lights illuminate the work area perfectly. Ideal for use in shift operation.

Metal separation

Pieces of metal contained in the material are attracted and extracted by powerful head roller magnets.



wind sifter

We also offer an add-on wind sifter option for absolute material purity.

Open for new ideas

Individual customer requests are possible after examination. We look forward to your challenges.

Important parameters at a glance

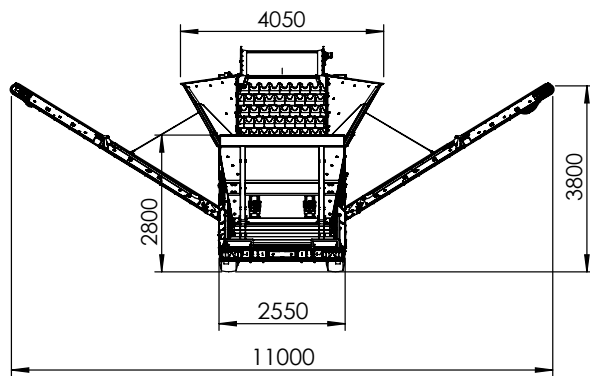

dimensions working position

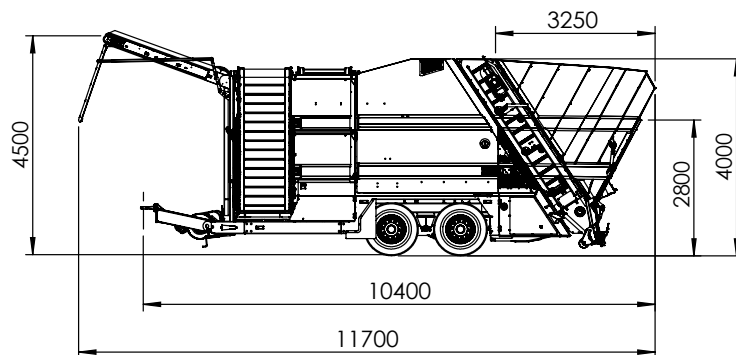

Technical data FLEXSTAR 3000

Transport dimensions	(LxWxH) 10400/2550/4000	Equipment
Engine		Hydr. conveyor operation <input checked="" type="checkbox"/>
Manufacturer	Perkins	Hydraulic support wheel <input checked="" type="checkbox"/>
Type	1204J-E44TA	Hydraulic hopper <input checked="" type="checkbox"/>
maximum Performance	117 kW / 159 HP	Air brake system with ABS <input checked="" type="checkbox"/>
Cylinder quantity	R4	Drawbar eye (diameter 50 mm) <input checked="" type="checkbox"/>
Emission	ECE Stufe V	Load sensing hydraulic system <input checked="" type="checkbox"/>
Chassis		24 volt lighting system <input checked="" type="checkbox"/>
	2 axle central chassis for 80 km/h (50 m/h)	Exhaust gas treatment DOC / DPF / SCR <input checked="" type="checkbox"/>
Permissible Total Weight	19000 kg	Cooler fan reversable <input checked="" type="checkbox"/>
Hopper <input checked="" type="checkbox"/>		Remote control <input type="checkbox"/>
Height	2800 mm	Central lubrication system <input type="checkbox"/>
Width	4050 mm	Crawling speed drive <input type="checkbox"/>
Volume (content)	8 m ³	LED-Working Lights <input checked="" type="checkbox"/>
Doser <input checked="" type="checkbox"/>		Magnetic separation (fine-, medium-, oversize conveyor) <input type="checkbox"/>
	infinitely variable speed	Tow ring shoe <input type="checkbox"/>
Coarse screenstage (compl. exchangeable) <input checked="" type="checkbox"/>		Special Paint <input type="checkbox"/>
Screening surface	5 m ²	Biological-Hydraulic-Oil <input type="checkbox"/>
Flex shafts	12 pcs.	Duomatic - quick coupling <input type="checkbox"/>
Weight	1600 kg	
Fine screenstage (compl. exchangeable) <input checked="" type="checkbox"/>		
Screening surface	7,5 m ²	
Flex shafts	18 pcs.	
Weight	2700 kg	
Oversize grain conveyor		
Discharge height	4500 mm	
Middle grain and fine grain conveyor		
Overhead discharge height	3800 mm	
Throughput capacity	(up to) 200 m ³ /h	

● series | ○ option

All the functions marked with can be operated via the optional radio remote control.

The specified parameters refer to the standard machine. Dimensions and specifications can differ due to equipment options.

Material quality



CONVINCING SCREENING QUALITY FOR MANY MATERIALS

The actual screening process of the WILLIBALD screening technology works as follows: The initial material to be screened is filled into the feeding hopper by a wheel loader. The material is fed over the roller floor in controlled doses to the star shafts. The feeding speed is continuously adjustable. The coarse fraction (overgrain) is separated by the first screening deck and discharged by a rubber belt. The finer material falls onto the second screening deck and is separated again into medium and fine grain. The acquired fractions are discharged to the left and right of the machine by conveyor belts with a discharge height of approx. 3.80 m. The screening machine can also be driven by a crawling speed drive (option). Depending on the type, grain and moisture content of the initial material, 90 to 200 cubic meters per hour can be screened out.

SOME INITIAL MATERIALS WHICH THE FLEXSTAR SCREENS OUT EXCELLENTLY:



THE END MATERIAL AFTER THE SCREENING PROCESS SHOWN BY SHREDDED GREEN WASTE

Division of the screening result into fine, medium and overgrain:

